

WARNING

- 1) The drawings are only a helping visual guide but do not replace, common sense, expertise, experience or craftsmanship.
- 2) If you do not have a minimum of mechanical skills, do not start self-learning with your CCR, it would be more expensive than sending it to a service center and probably dangerous for yourself.
- 3) If you decide to keep going doing your own maintenance and in doubt, always refer to your instructor, an authorized service center or the factory.
- 4) If you reached this line and still want to keep going here you have a few tips:

Use only high quality handtools (do not use electrical driven tools) high quality tool sets are cheaper than any JJ part.

Grease O-rings properly

Acetal resin is strong but not stronger than steel or aluminum, do not overtight screws over Acetal, once ruined it goes to the trash bin.

Many threads are made with Helicoil inserts, if damaged or broken they should be replaced, for doing this, a special set of tools is needed. Send the part to the factory or to a service center. Do not try to replace it yourself, you are going to ruin something.

If you figure out the O-ring sizes, do not buy commercial ones (buy originals from JJ) You do not know the right cord diameter, the material or the right Hardness Shore.

List of tools

Allen key 3mm

Allen key 5mm

Torx screwdriver #10

Torx screwdriver #20

Torx screwdriver #30

Philips screwdriver #1

Wrench 10mm

Wrench 12mm

Wrench 14mm

O-ring picker

Ref.	Qty	Title/Name/Design/Material	Art. Number/Ref		
Designed by ff	Checked by ff	Approved by - date ff - 20/02/20	Filename tips	Date 20/02/20	Scale 1:1
tridens advanced engineering solutions			Notes		

Loop end T side

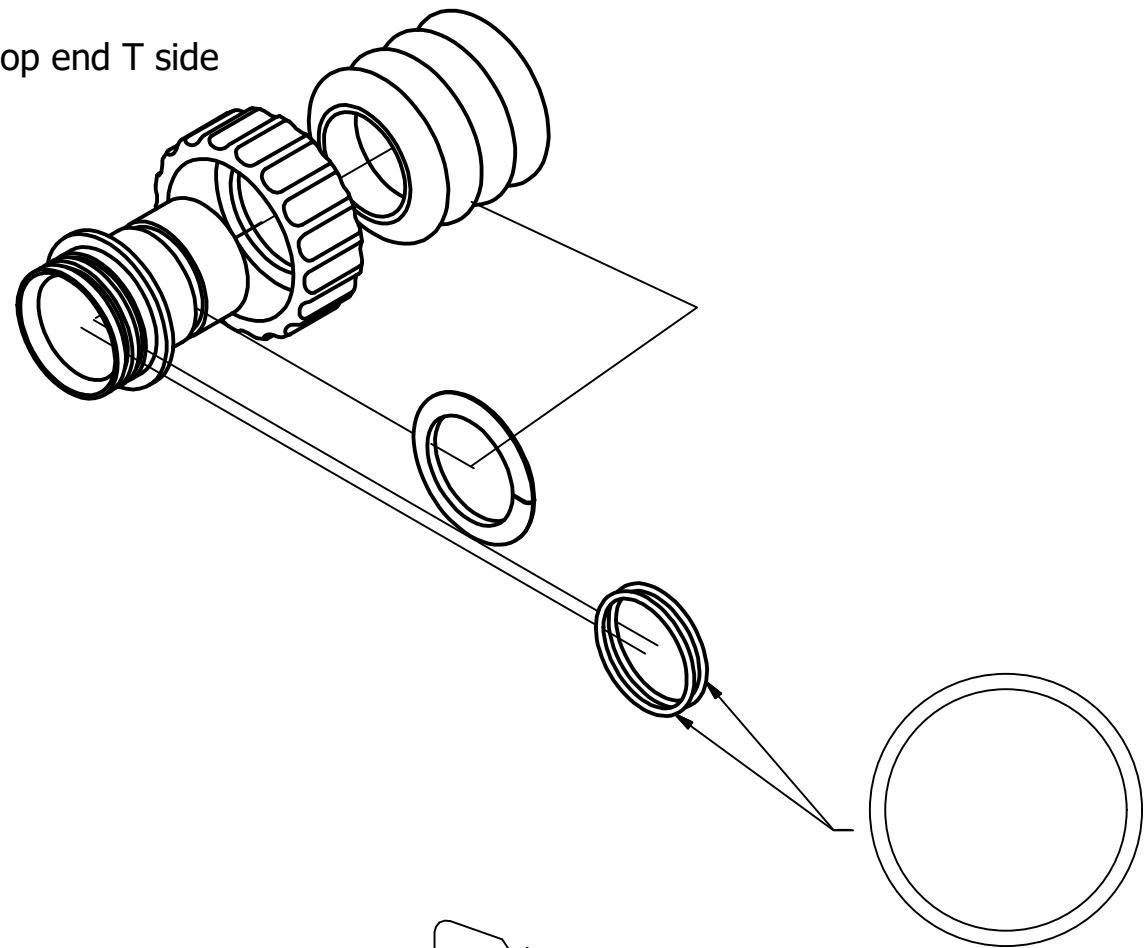

Check correct printing size with this 100mmx100mm square template

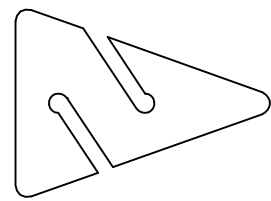
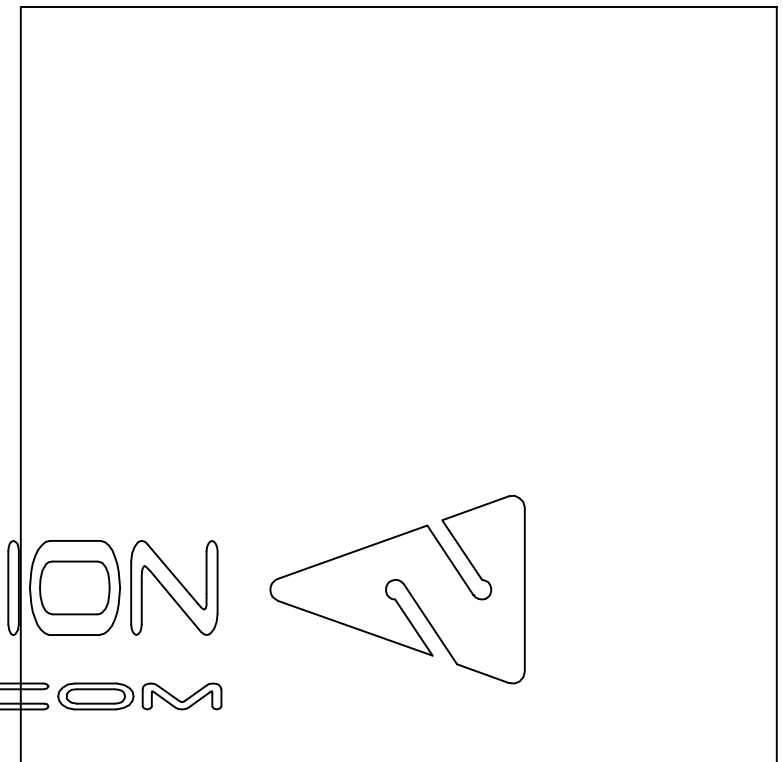

TEK DIVING NATION

TEKDIVINGNATION.COM

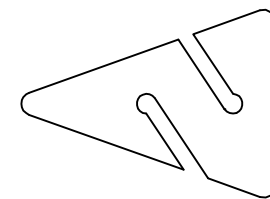

Loop end DSV side

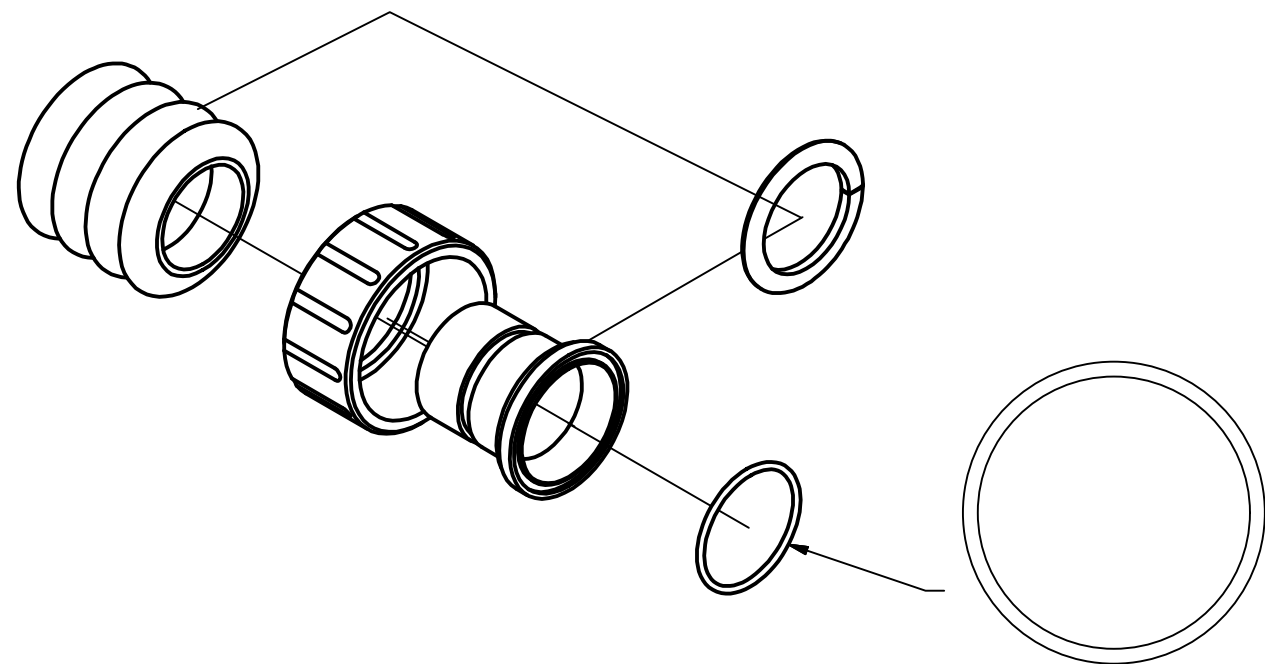

Liability release

This drawing has been drafted with accuracy in order to help with the Loop maintenance, but this is not an official JJ release.

In case of doubt we strongly suggest to contact your instructor.

We decline any responsibility for any non official maintenance service.

Ref.	Qty	Title/Name/Design/Material			Art. Number/Ref	
Designed by ff	Checked by ff	Approved by - date ff - 20/02/20	Filename Ends assbly	Date 20/02/20	Scale 1:1	
tridens advanced engineering solutions			Loop ends			
				exploded view	Edition 0	Sheet 1/1

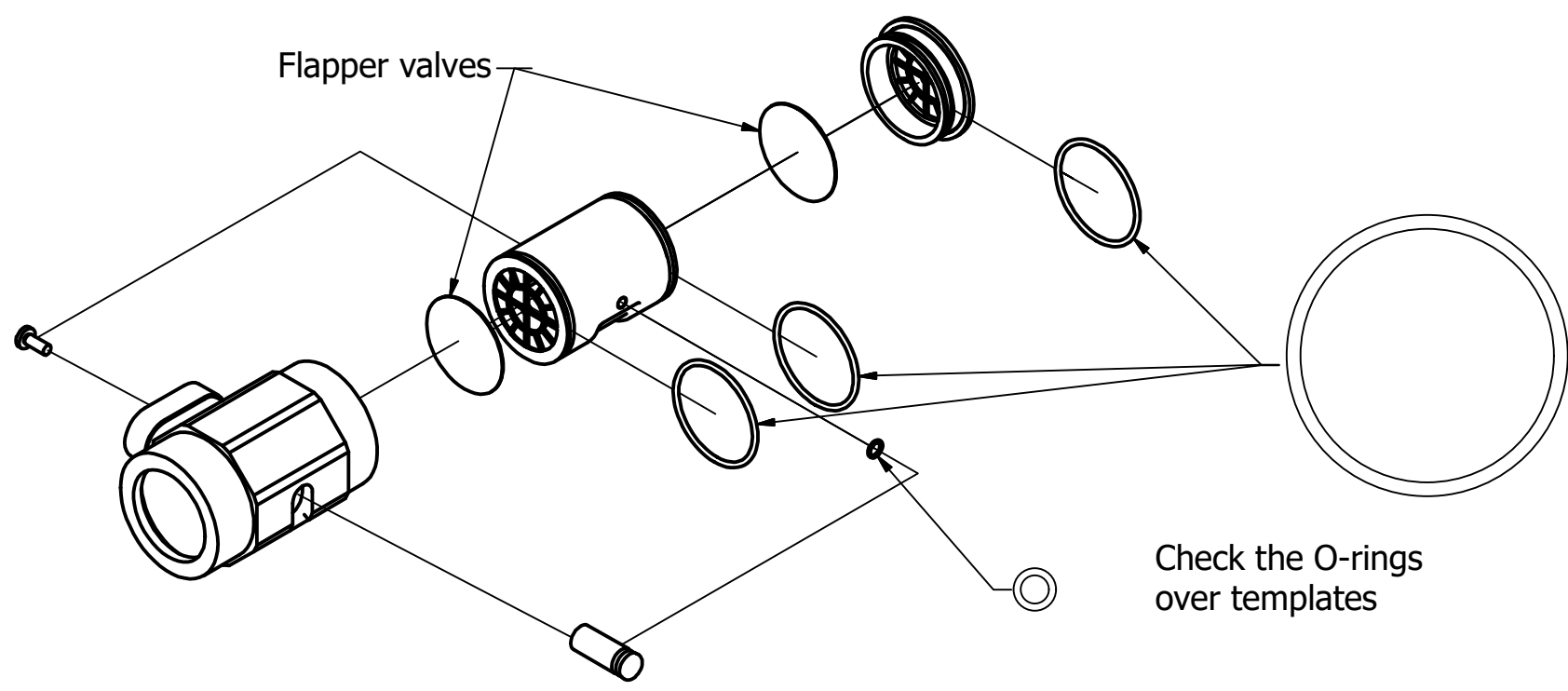

Flapper valves

Check the O-rings over templates

Check correct printing size with this 100mmx100mm square template

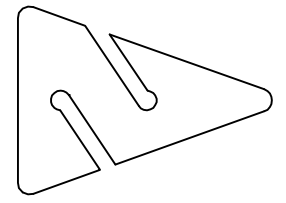
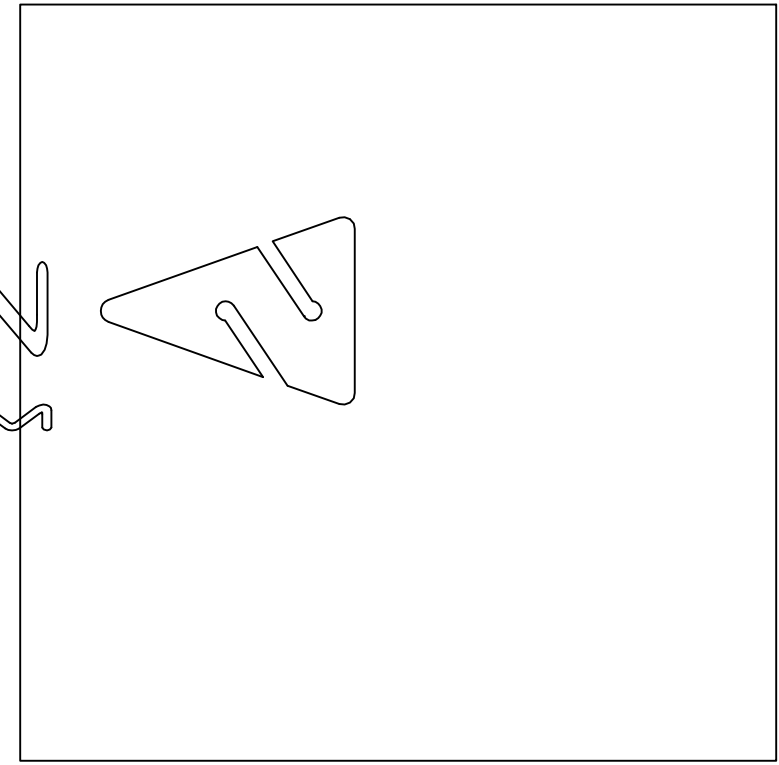

TEK DIVING NATION
TEKDIVINGNATION.COM

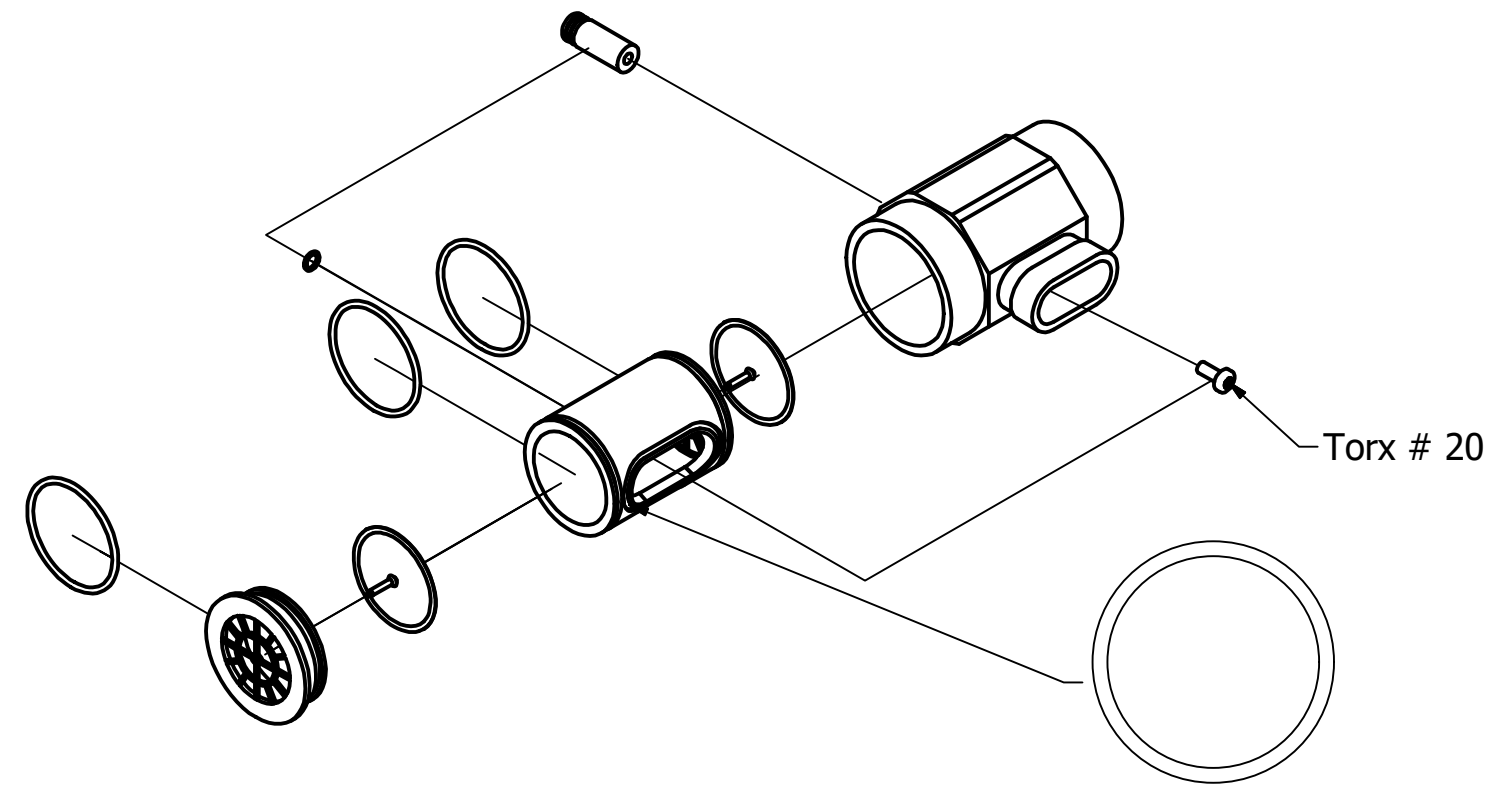
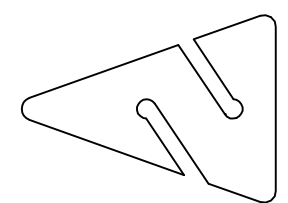

Torx # 20

Pay close attention when assembling to avoid O-ring extrusion

Liability release
This drawing has been drafted with accuracy in order to help with the DSV maintenance, but this is not an official JJ release. In case of doubt we strongly suggest to contact your instructor. We decline any responsibility for any non official maintenance service.

Ref.	Qty	Title/Name/Design/Material	Art. Number/Ref		
Designed by ff	Checked by ff	Approved by - date ff - 20/02/20	Filename DSV assbly	Date 20/02/20	Scale 1:1
tridens advanced engineering solutions			DSV		
			exploded view		Edition 0

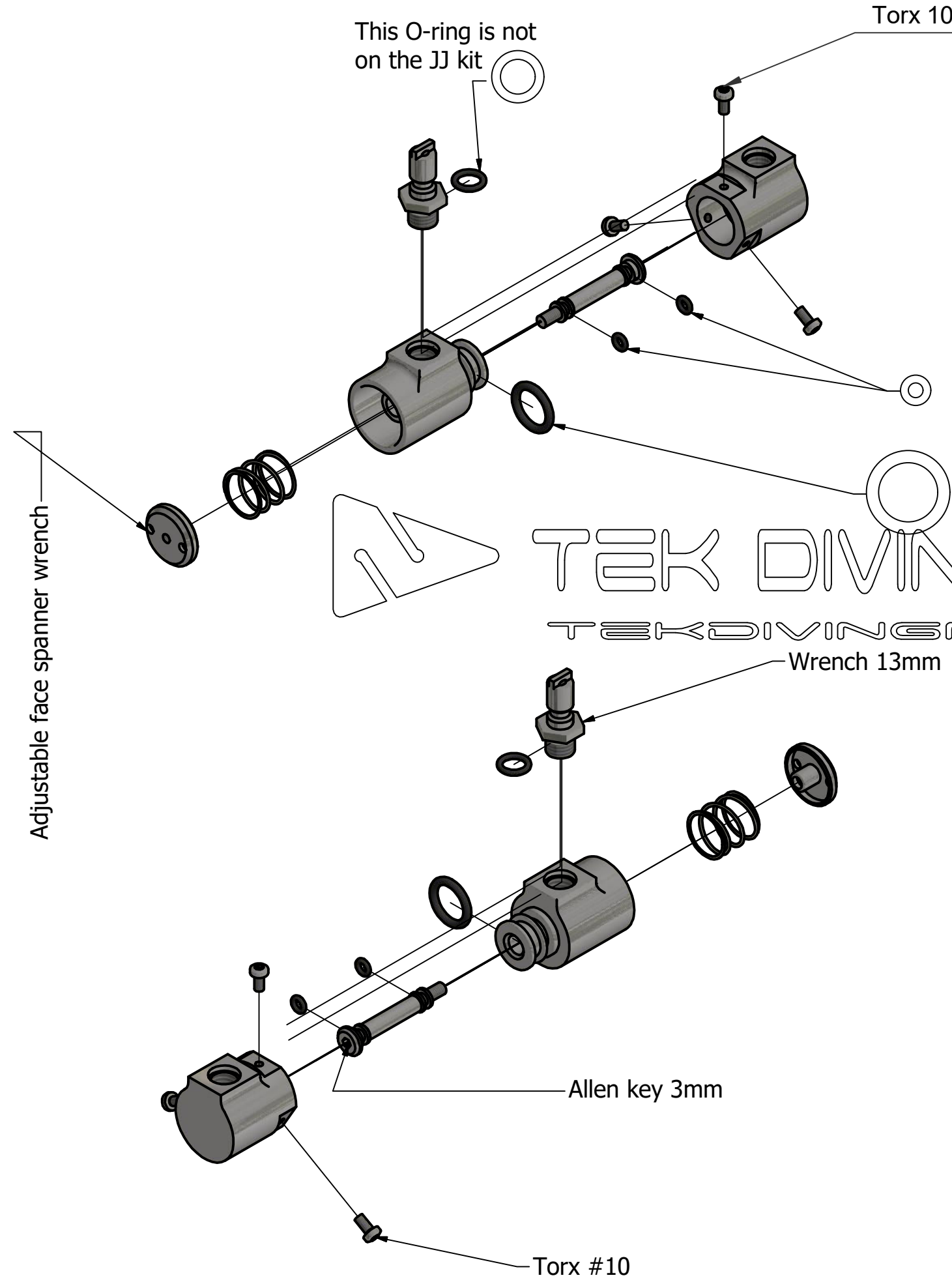

Check correct printing size with this 100mmx100mm square template

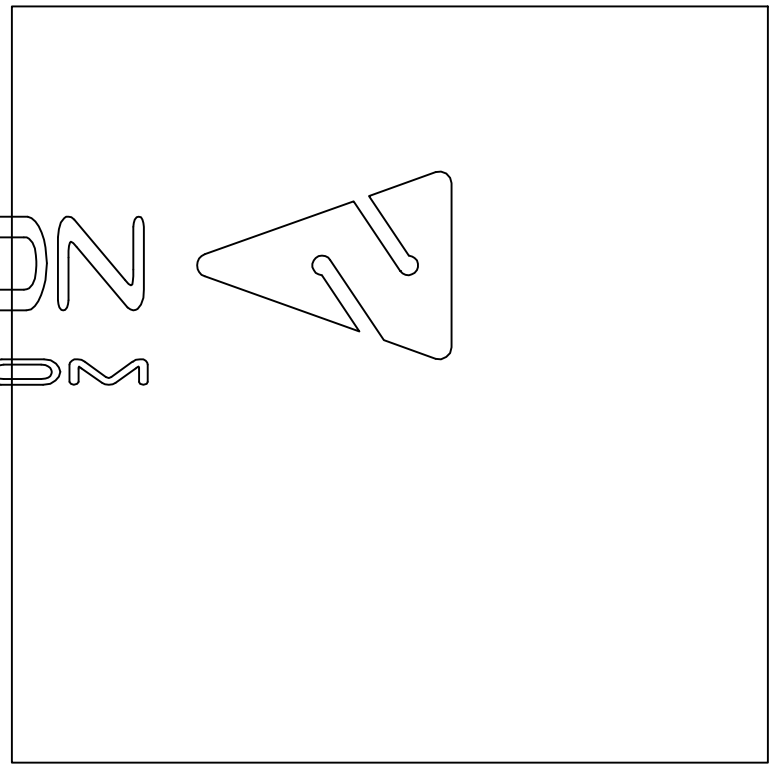

TEK DIVING NATION
TEKDIVINGNATION.COM

Liability release
This drawing has been drafted with accuracy in order to help with the MAV maintenance, but this is not an official JJ release.
In case of doubt we strongly suggest to contact your instructor.
We decline any responsibility for any non official maintenance service.

Ref.	Qty	Title/Name/Design/Material			Art. Number/Ref
Designed by ff	Checked by ff	Approved by - date ff - 20/02/20	Filename MAV assembly	Date 20/02/20	Scale 1:1
tridens advanced engineering solutions			MAV exploded view		
				Edition 0	Sheet 1/1

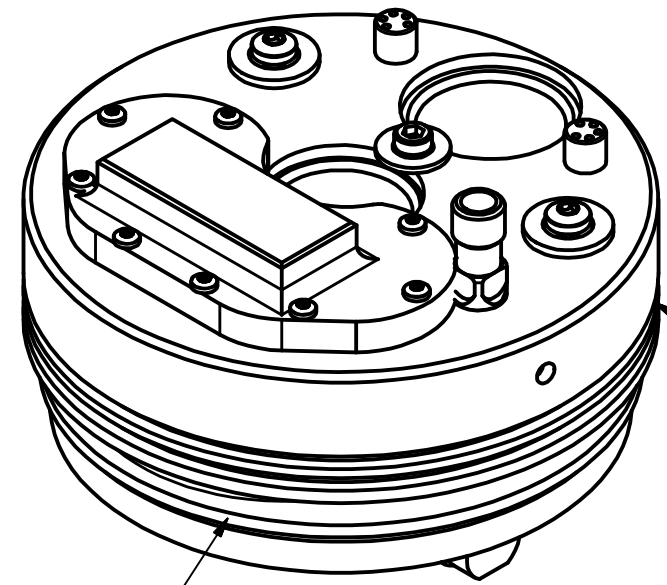

Head to canister

Check the O-rings over templates

Check correct printing size with this 100mmx100mm square template

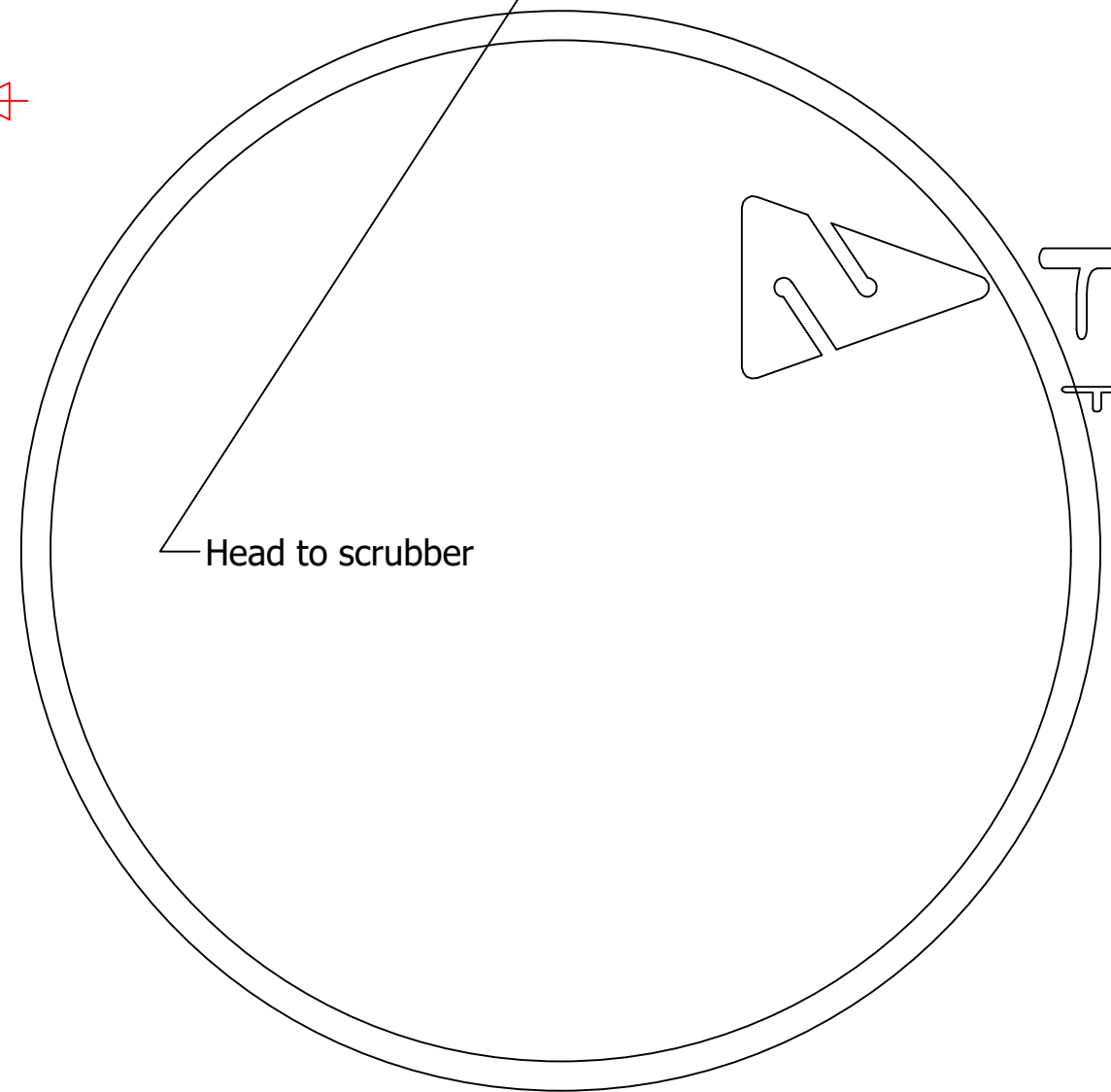

Head to scrubber

TEK DIVING NATION
TEKDIVINGNATION.COM

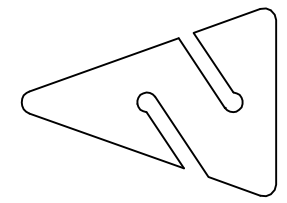

Liability release
 This drawing has been drafted with accuracy in order to help with the Head maintenance, but this is not an official JJ release.
 In case of doubt we strongly suggest to contact your instructor.
 We decline any responsibility for any non official maintenance service.

Ref.	Qty	Title/Name/Design/Material			Art. Number/Ref	
Designed by ff	Checked by ff	Approved by - date ff - 20/02/20	Filename head assbly	Date 20/02/20	Scale 1:1	
tridens advanced engineering solutions			Head assembly			
exploded view				Edition 0	Sheet 1/1	

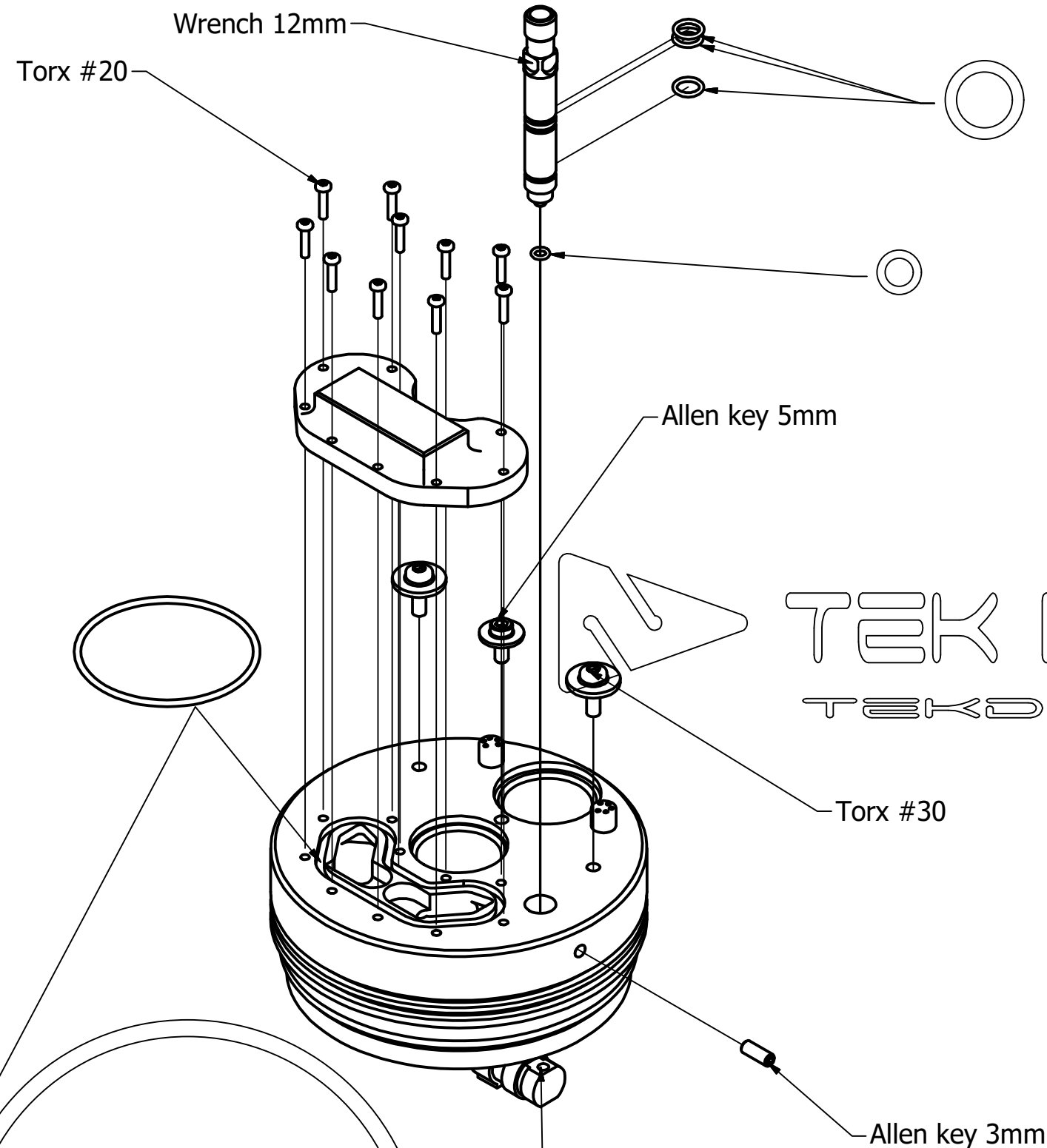

Check correct printing size with this 100mmx100mm square template

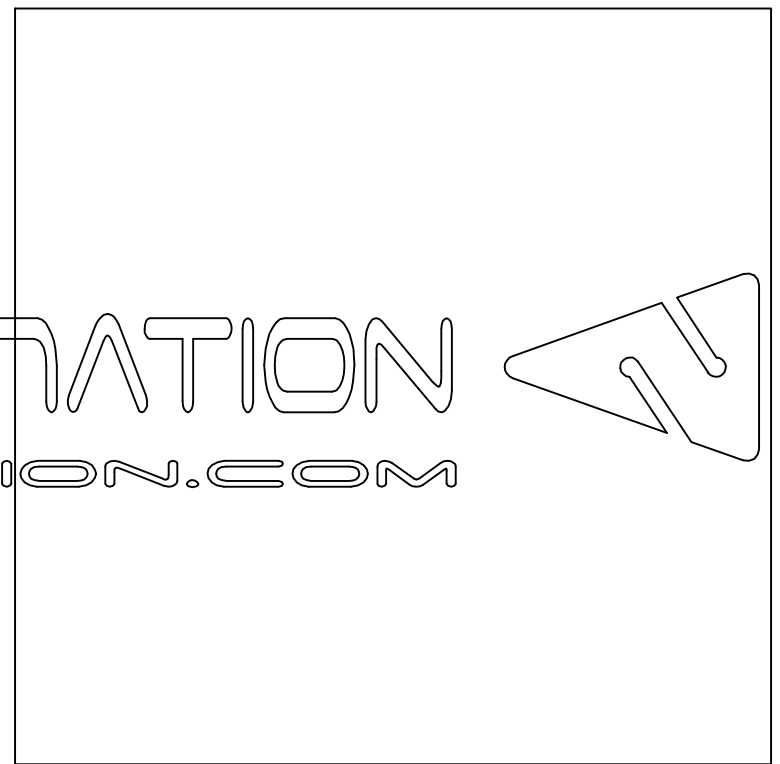

Check the O-rings over templates

TEK DIVING NATION
TEKDIVINGNATION.COM

Liability release
 This drawing has been drafted with accuracy in order to help with the Head maintenance, but this is not an official JJ release.
 In case of doubt we strongly suggest to contact your instructor.
 We decline any responsibility for any non official maintenance service.

WARNING
 Both sides of the solenoid have the same thread, only one is the right inlet.
 Be sure that you are connecting the right one.
 Be sure connections is tight to avoid Oxygen leaks.

Ref.	Qty	Title/Name/Design/Material	Art. Number/Ref
Designed by ff	Checked by ff	Approved by - date ff - 20/02/20	Filename head assbly
tridens advanced engineering solutions		Head assembly	
exploded view			Edition 0
			Sheet 1/1

A
B
C
D
E
F

A
B
C
D
E
F

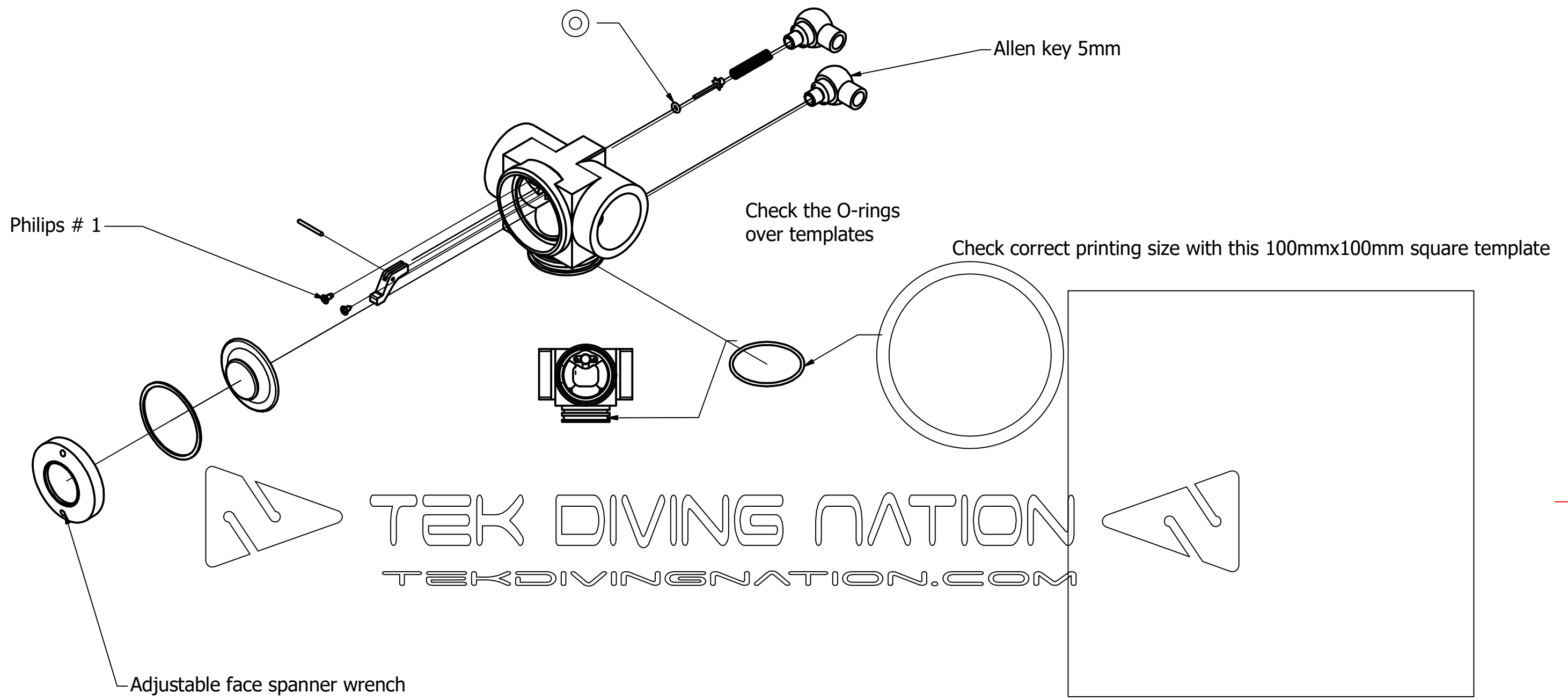

Liability release
 This drawing has been drafted with accuracy in order to help with the T maintenance, but this is not an official JJ release.
 In case of doubt we strongly suggest to contact your instructor.
 We decline any responsibility for any non official maintenance service.

Ref.	Qty	Title/Name/Design/Material			Art. Number/Ref	
Designed by ff	Checked by ff	Approved by - date ff - 20/02/20	Filename insp T assbly	Date 20/02/20	Scale 1:1	
tridens advanced engineering solutions			Inspiration side T			
exploded view				Edition 0	Sheet 1/1	

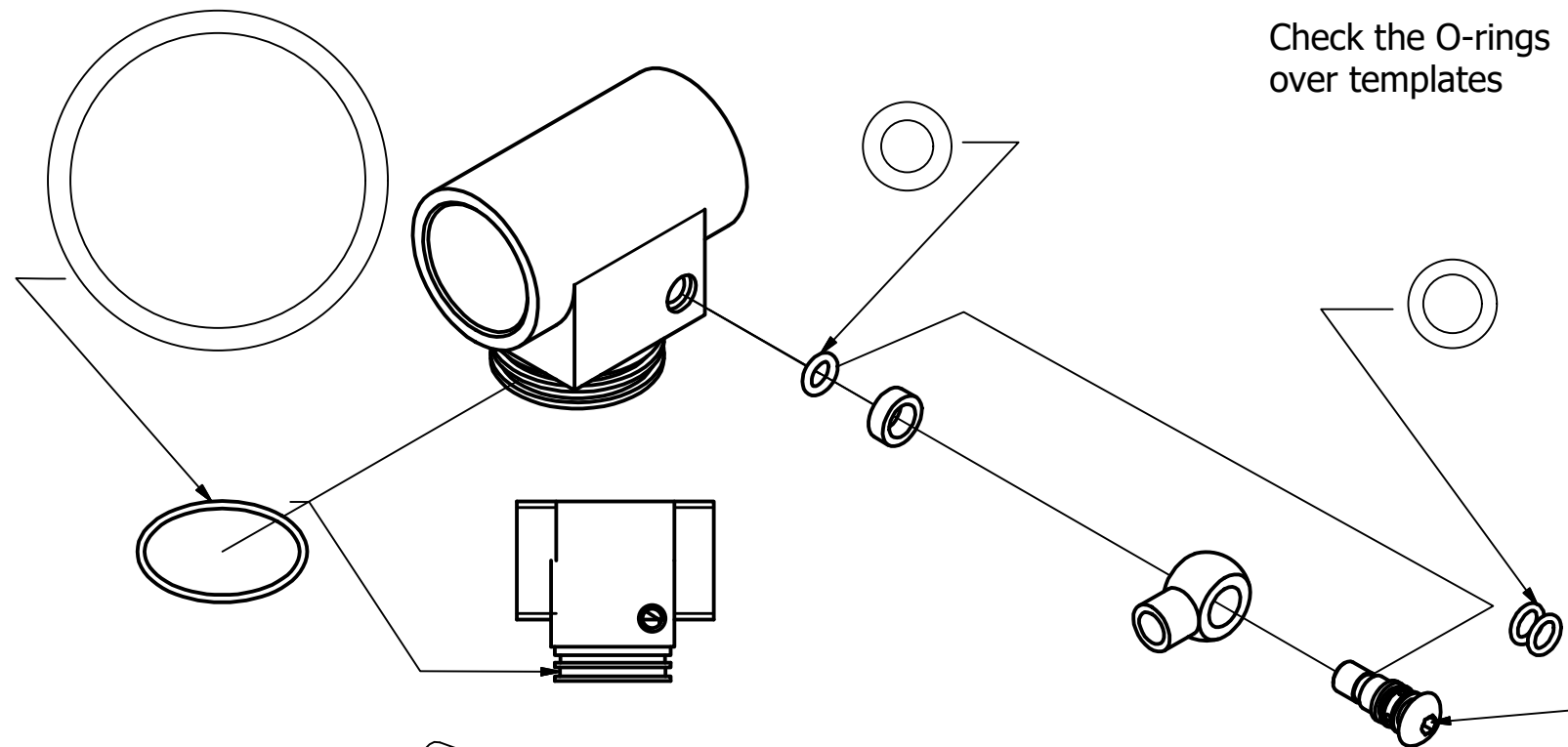

Check correct printing size with this 100mmx100mm square template

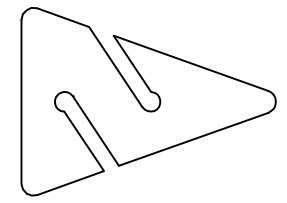
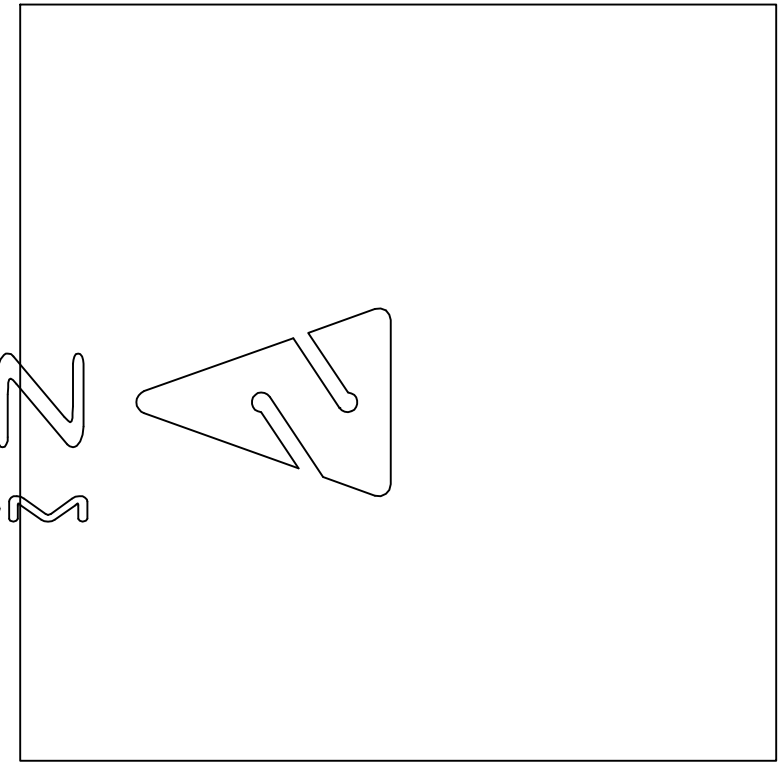

TEK DIVING NATION
TEKDIVINGNATION.COM

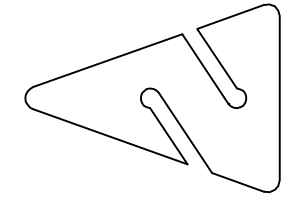

Liability release
 This drawing has been drafted with accuracy in order to help with the T maintenance, but this is not an official JJ release.
 In case of doubt we strongly suggest to contact your instructor.
 We decline any responsibility for any non official maintenance service.

Ref.	Qty	Title/Name/Design/Material			Art. Number/Ref	
Designed by ff	Checked by ff	Approved by - date ff - 20/02/20	Filename exp T assbly	Date 20/02/20	Scale 1:1	
tridens advanced engineering solutions			Expiration side T			
				exploded view	Edition 0	Sheet 1/1

TEK DIVING NATION

TEKDIVINGNATION.COM

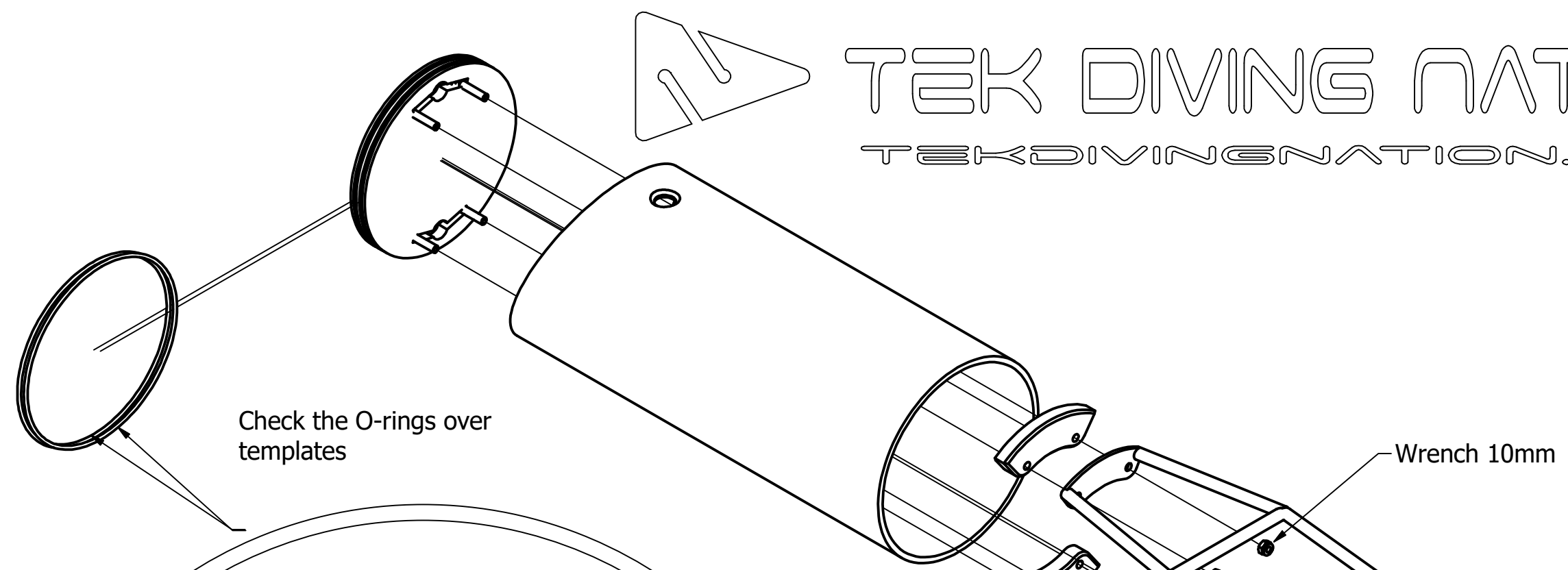
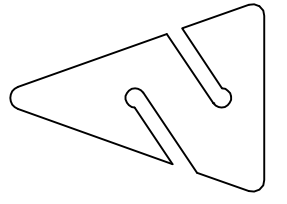
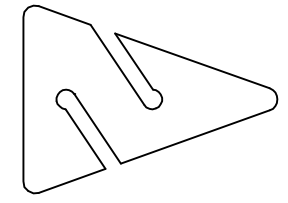

Check the O-rings over templates

Wrench 10mm

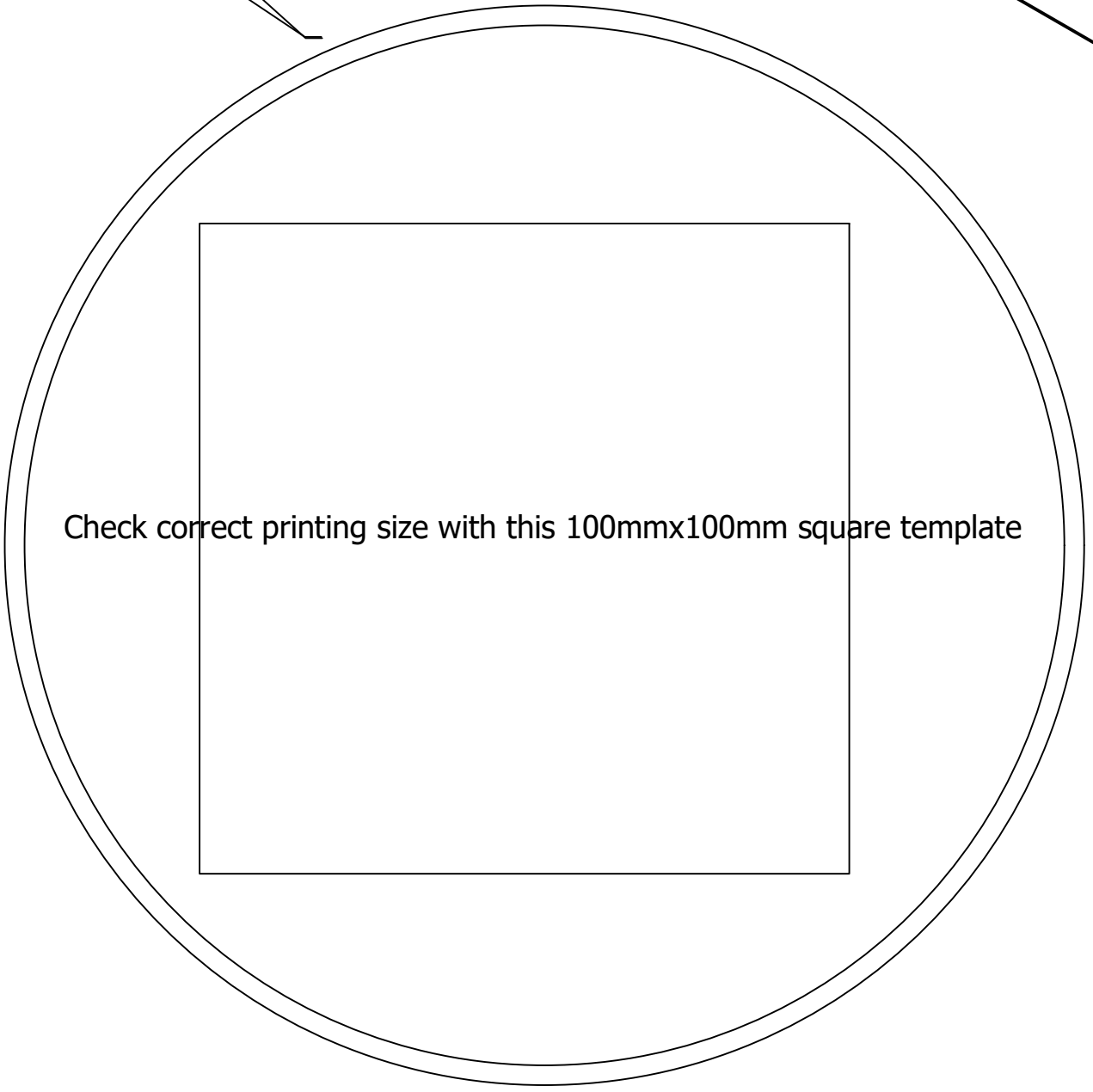

Check correct printing size with this 100mmx100mm square template

Marks must match

Liability release
 This drawing has been drafted with accuracy in order to help with the Bottom plate maintenance, but this is not an official JJ release.
 In case of doubt we strongly suggest to contact your instructor.
 We decline any responsibility for any non official maintenance service.

Ref.	Qty	Title/Name/Design/Material			Art. Number/Ref	
Designed by ff	Checked by ff	Approved by - date ff - 00/00/00	Filename bplteassbly	Date 00/00/00	Scale 1:1	
tridens advanced engineering solutions			Bottom plate			
exploded view				Edition 0	Sheet 1/1	